

JVC



ENGLISH

ESPAÑOL

CD RECEIVER

KD-S32

RECEPTOR CON CD

KD-S32

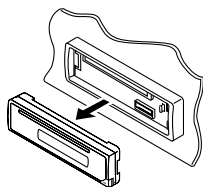
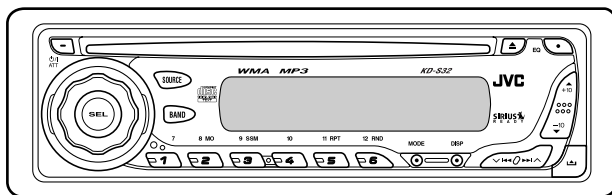
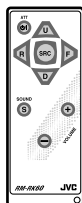

SIRIUS
READY

MP3
WMA

COMPACT
disc
DIGITAL AUDIO
TEXT



For canceling the display demonstration, see page 8.
Para cancelar la demostración en pantalla, consulte la página 8.

For installation and connections, refer to the separate manual.
Para la instalación y las conexiones, refiérase al manual separado.

INSTRUCTIONS MANUAL DE INSTRUCCIONES

For customer Use:

Enter below the Model No. and Serial No. which are located on the top or bottom of the cabinet. Retain this information for future reference.

Model No. _____

Serial No. _____

GET0321-001A

[J]

Thank you for purchasing a JVC product.

Please read all instructions carefully before operation, to ensure your complete understanding and to obtain the best possible performance from the unit.

INFORMATION (For U.S.A.)

This equipment has been tested and found to comply with the limits for a Class B digital device, pursuant to Part 15 of the FCC Rules. These limits are designed to provide reasonable protection against harmful interference in a residential installation. This equipment generates, uses, and can radiate radio frequency energy and, if not installed and used in accordance with the instructions, may cause harmful interference to radio communications. However, there is no guarantee that interference will not occur in a particular installation. If this equipment does cause harmful interference to radio or television reception, which can be determined by turning the equipment off and on, the user is encouraged to try to correct the interference by one or more of the following measures:

- Reorient or relocate the receiving antenna.
- Increase the separation between the equipment and unit.
- Connect the equipment into an outlet on a circuit different from that to which the receiver is connected.
- Consult the dealer or an experienced radio/TV technician for help.

IMPORTANT FOR LASER PRODUCTS

1. CLASS 1 LASER PRODUCT
2. **CAUTION:** Do not open the top cover. There are no user serviceable parts inside the unit; leave all servicing to qualified service personnel.
3. **CAUTION:** Visible and invisible laser radiation when open and interlock failed or defeated. Avoid direct exposure to beam.

Warning:

If you need to operate the unit while driving, be sure to look ahead carefully or you may be involved in a traffic accident.

How to reset your unit

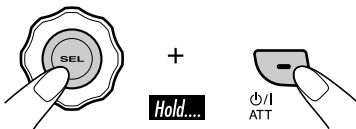

- This will reset the microcomputer. Your preset adjustments will also be erased.
- If a disc is loaded, it will eject. Be careful not to drop the disc.

How to forcibly eject a disc

If a disc cannot be recognized or cannot be ejected, eject the disc as follows.



- If this does not work, reset your unit.
- Be careful not to drop the disc when it ejects.

Contents

How to reset your unit	2	Sound adjustments	16
How to forcibly eject a disc	2	Selecting preset sound modes	
How to read this manual	4	(C-EQ: custom equalizer)	16
How to use the MODE button	4	Adjusting the sound	16
How to detach/attach the control panel	4	General settings — PSM	17
Control panel — KD-S32	5	Basic operations	17
Parts identification	5	External component operations... 19	
Remote controller — RM-RK60 ... 6	6	Playing an external component	19
Main elements and features	6	SIRIUS® radio operations..... 20	
Getting started..... 7	7	Listening to the SIRIUS® radio..... 21	
Basic operations..... 7	7	Storing channels in memory	21
Canceling the display demonstrations ...	8	Listening to a preset channel	21
Setting the clock	8	Maintenance	22
Radio operations	9	More about this unit..... 23	
Listening to the radio..... 9	9	Troubleshooting	25
Storing stations in memory	9	Specifications	27
Listening to a preset station	10		
Disc operations	11		
Playing a disc in the unit	11		
Playing discs in the CD changer	12		
Other main functions	13		
Changing the display information	14		
Selecting the playback modes.....	15		

For safety....

- Do not raise the volume level too much, as this will block outside sounds, making driving dangerous.
- Stop the car before performing any complicated operations.



Temperature inside the car....

If you have parked the car for a long time in hot or cold weather, wait until the temperature in the car becomes normal before operating the unit.

How to read this manual

The following methods are used to make the explanations simple and easy-to-understand:

- Some related tips and notes are explained in “More about this unit” (see page 23).
- Button operations are mainly explained with the illustrations as follows:

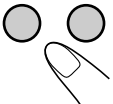
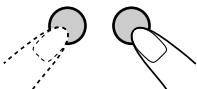
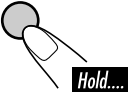
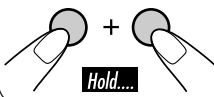
	Press briefly.
	Press repeatedly.
	Press either one.
	
	Press and hold until your desired response begins.
	Press and hold both buttons at the same time.

How to use the MODE button

If you press MODE, the unit goes into functions mode, then the number buttons and ▲/▼ buttons work as different function buttons.

Ex.: When number button 2 works as MO (monaural) button.

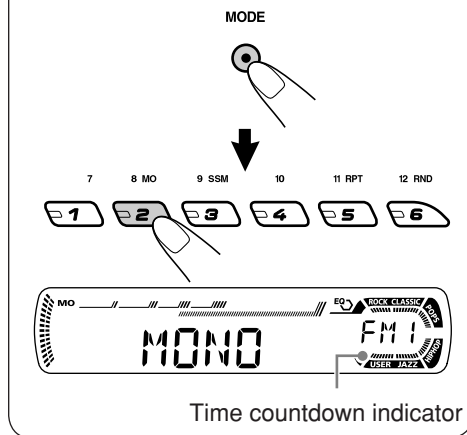

To use these buttons for their original functions again after pressing MODE, wait for 5 seconds without pressing any of these buttons until the functions mode is cleared.

- Pressing MODE again also clears the functions mode.

How to detach/attach the control panel

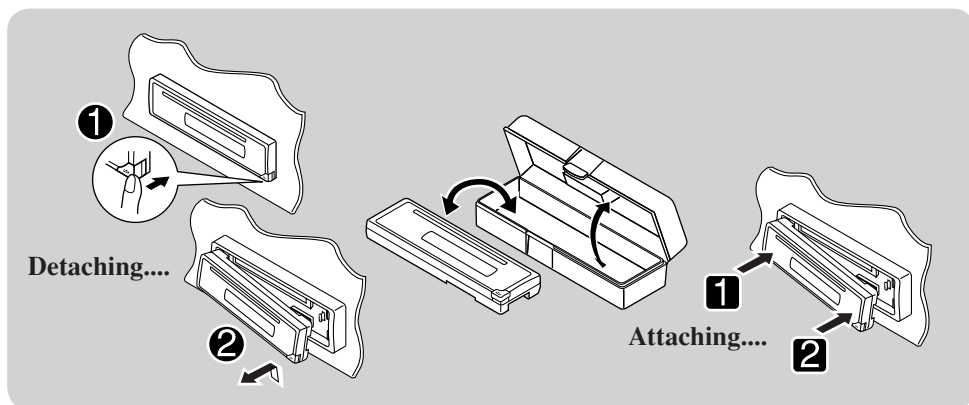

Parts identification

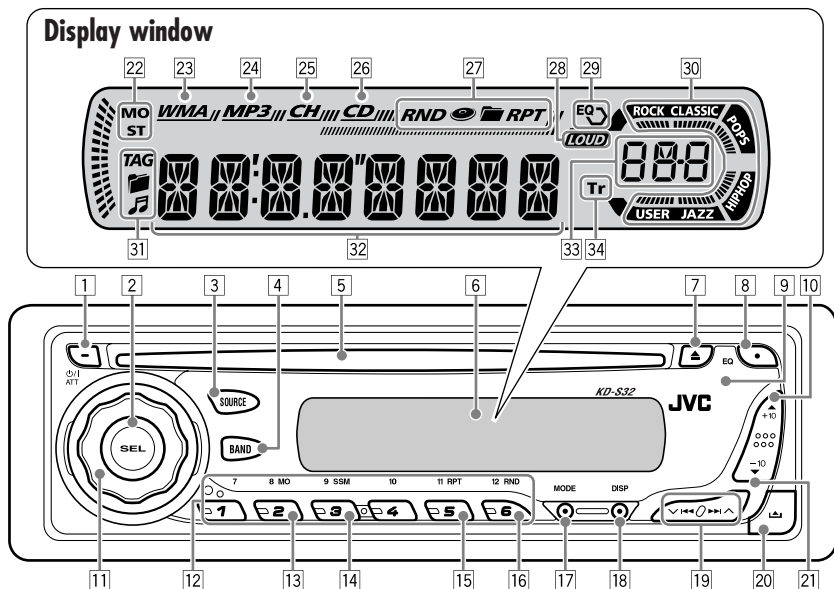

- 1 ϕ /I ATT (standby/on attenuator) button
- 2 SEL (select) button
- 3 SOURCE button
- 4 BAND button
- 5 Loading slot
- 6 Display window
- 7 \blacktriangle (eject) button
- 8 EQ (equalizer) button
- 9 Remote sensor
 - *DO NOT* expose the remote sensor to strong light (direct sunlight or artificial lighting).
- 10 \blacktriangle (up) button / +10 button
- 11 Control dial
- 12 Number buttons
- 13 MO (monaural) button
- 14 SSM (Strong-station Sequential Memory) button
- 15 RPT (repeat) button
- 16 RND (random) button
- 17 MODE button
- 18 DISP (display) button
- 19 \blacktriangledown | \blacktriangleleft / \blacktriangleright | \blacktriangleup buttons
- 20 \blacktriangle (control panel release) button
- 21 \blacktriangledown (down) button / -10 button

Display window

- 22 Tuner reception indicators—
MO (monaural), ST (stereo)
- 23 WMA indicator
- 24 MP3 indicator
- 25 CH (CD changer) indicator
 - *Lights up only when CD-CH is selected for the playback source.*
- 26 CD indicator
- 27 Playback mode / item indicators—
RND (random), (disc), (folder), RPT (repeat)
- 28 LOUD (loudness) indicator
- 29 EQ (equalizer) indicator
- 30 Sound mode (C-EQ: custom equalizer) indicators—ROCK, CLASSIC, POPS, HIP HOP, JAZZ, USER
 - *||||| also works as the time countdown indicator.*
- 31 Disc information indicators—TAG (ID3 Tag), (folder), (track/file)
- 32 Main display
- 33 Source display / Volume level indicator
- 34 Tr (track) indicator

Installing the lithium coin battery (CR2025)

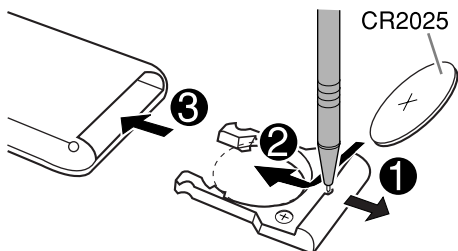

- Aim the remote controller directly at the remote sensor on the unit. Make sure there is no obstacle in between.

Warning:

- Do not install any battery other than CR2025 or its equivalent; otherwise, it may explode.
- Store the battery in a place where children cannot reach to avoid risk of accident.
- To prevent the battery from over-heating, cracking, or starting a fire:
 - Do not recharge, short, disassemble, heat the battery, or dispose of it in a fire.
 - Do not leave the battery with other metallic materials.
 - Do not poke the battery with tweezers or similar tools.
 - Wrap the battery with tape and insulate when throwing away or saving it.

Caution:

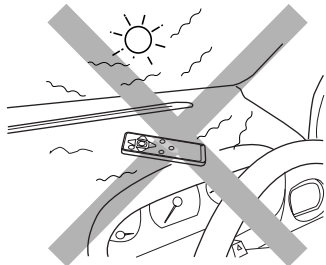

Main elements and features

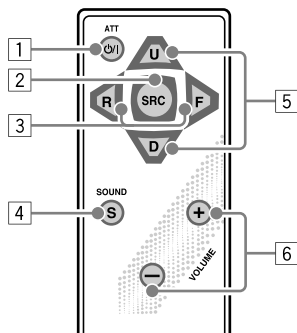

- 1** Φ /I ATT (standby/on attenuator) button
 - Turns the power on if pressed briefly or attenuates the sound when the power is on.
 - Turns the power off if pressed and held.
- 2** SRC (source) button
 - Selects the source.
- 3** R (reverse) / F (forward) buttons
 - Searches for stations if pressed briefly.
 - Fast-forwards or reverses the track if pressed and held.
 - Changes the tracks of the disc.
 - While listening to the SIRIUS radio:
 - Changes the channels if pressed briefly.
 - Changes the channels rapidly if pressed and held.
- 4** SOUND button
 - Selects the sound mode (C-EQ: custom equalizer).
- 5** U (up) / D (down) buttons
 - Changes the FM/AM bands with U (up) only.
 - Changes the preset stations with D (down) only.
 - Changes the folder of the MP3/WMA discs.
 - While playing an MP3 disc on an MP3-compatible CD changer:
 - Changes the disc if pressed briefly.
 - Changes the folder if pressed and held.
 - While listening to the SIRIUS radio:
 - Changes the categories.
- 6** VOLUME +/- buttons
 - Adjusts the volume level.

Getting started

Basic operations

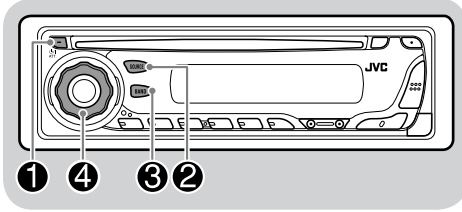

4 Adjust the volume.

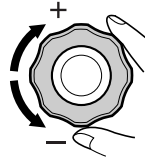

Volume level appears.

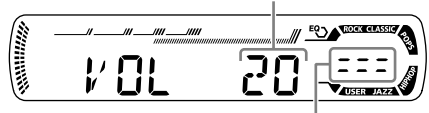

Volume level indicator

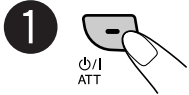

⏻/ATT



SOURCE

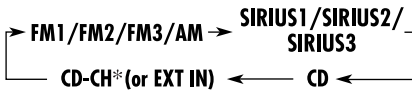

You cannot select some sources if they are not ready.

3 • For FM/AM tuner

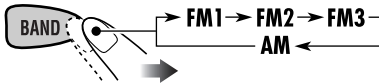

• For SIRIUS® radio

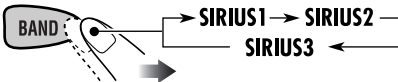

* Select "CD-CH" when using an Apple iPod® or a JVC D. player (see page 19).

iPod is a registered trademark of Apple Computer, Inc.

5 Adjust the sound as you want. (See page 16.)

To drop the volume in a moment (ATT)

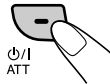

⏻/ATT

To restore the sound, press it again.

To turn off the power

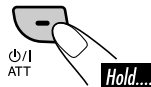

⏻/ATT

Hold...

Caution on volume setting:

Discs produce very little noise compared with other sources. Lower the volume before playing a disc to avoid damaging the speakers by the sudden increase of the output level.

Canceling the display demonstrations

If no operations are done for about 20 seconds, display demonstration starts.

[Initial: DEMO ON]—see page 17.

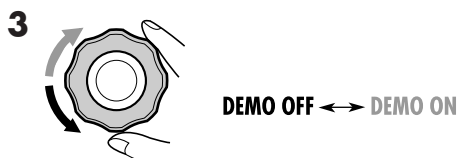
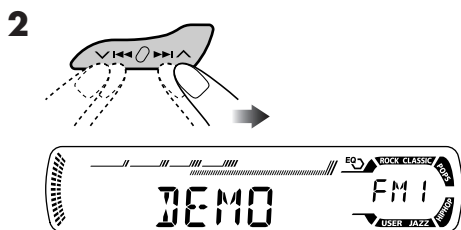

4 Finish the procedure.



To activate the display demonstration

In step **3** above...



Setting the clock



2 Set the hour and minute.

- 1 Select “CLOCK H” (hour), then adjust the hour.
- 2 Select “CLOCK M” (minute), then adjust the minute.

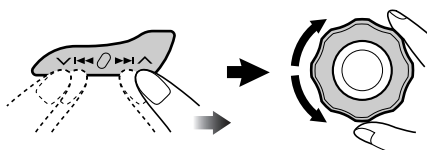

3 Finish the procedure.



To check the current clock time when the power is turned off

DISP



Radio operations

Listening to the radio

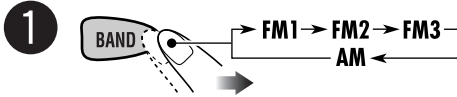
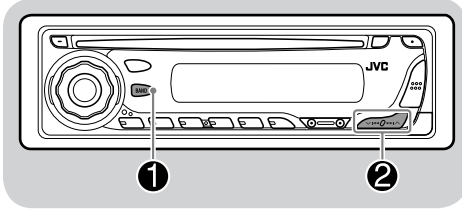

Lights up when receiving an FM stereo broadcast with sufficient signal strength.

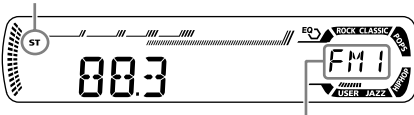

Selected band appears.

2 Start searching for a station.

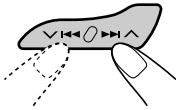

When a station is received, searching stops.

To stop searching, press the same button again.

To tune in to a station manually

In step 2 above...

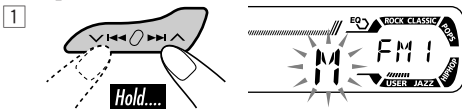

2 Select the desired station frequencies.

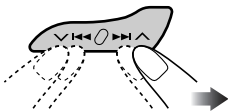

When an FM stereo broadcast is hard to receive

1 MODE



2 8 MO



Lights up when monaural mode is activated.

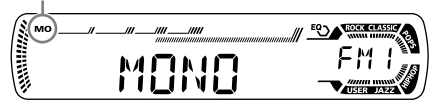

Reception improves, but stereo effect will be lost.

To restore the stereo effect, repeat the same procedure so that the MO indicator goes off.

Storing stations in memory

You can preset six stations for each band.

FM station automatic presetting—SSM (Strong-station Sequential Memory)

1



2 Select the FM band (FM1 – FM3) you want to store into.

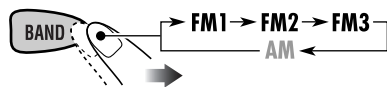

3 MODE



To be continued...

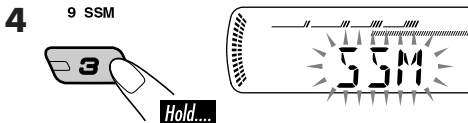

"SSM" flashes, then disappears when automatic presetting is over.

Local FM stations with the strongest signals are searched and stored automatically in the FM band.

Manual presetting

Ex.: Storing FM station of 92.5 MHz into preset number 4 of the FM1 band.

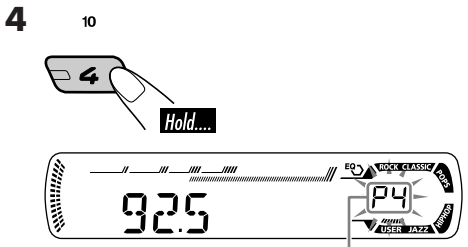
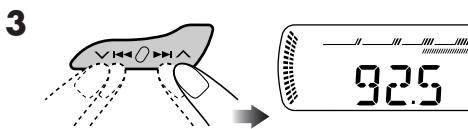
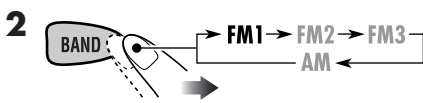
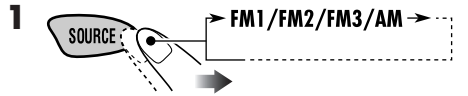

Preset number flashes for a while.

Listening to a preset station

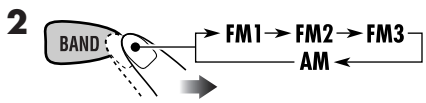
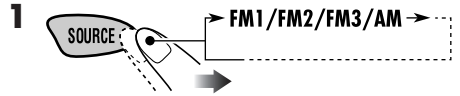

3 Select the preset station (1 – 6) you want.

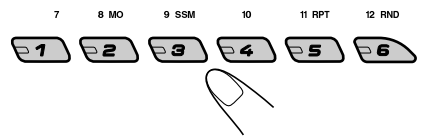

or

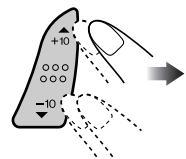

To check the current clock time while listening to an FM or AM station

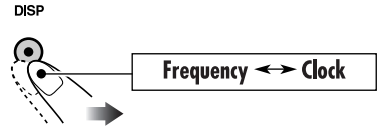

Disc operations

Playing a disc in the unit

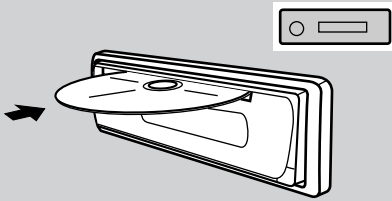

All tracks will be played repeatedly until you change the source or eject the disc.

About MP3 and WMA discs

MP3 and WMA (Windows Media® Audio) “tracks” (words “file” and “track” are used interchangeably) are recorded in “folders.”

- When inserting an MP3 or a WMA disc:

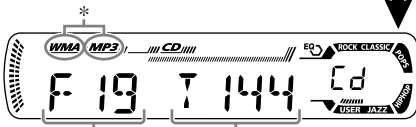

Total folder number Total file number

Disc information appears automatically (see page 14).

Selected folder number



Elapsed playing time Current track number

- When inserting an audio CD or a CD Text disc:



Total playing time of the inserted disc Total track number of the inserted disc

CD Text: Disc title/performer →
Track title appears automatically (see page 14).

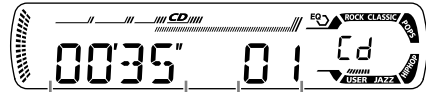

Elapsed playing time Current track number

To stop play and eject the disc



The following marks are used to indicate...

 : Built-in CD player operations.

 : External CD changer operations.

* Either the MP3 or WMA indicator lights up depending on the detected file.

Playing discs in the CD changer

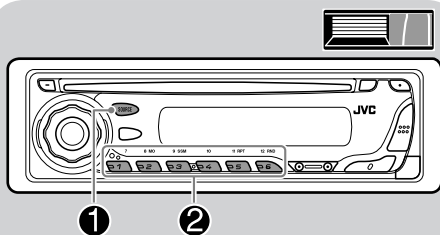

About the CD changer

It is recommended to use a JVC MP3-compatible CD changer with your unit.

- You can also connect other CH-X series CD changers (except CH-X99 and CH-X100). However, they are not compatible with MP3 discs, so you cannot play back MP3 discs.
- You cannot play any WMA disc in the CD changer.
- You cannot use the KD-MK series CD changers with this unit.
- Disc text information recorded in the CD Text can be displayed when a JVC CD Text compatible CD changer is connected.

All tracks of the inserted discs in the magazine will be played repeatedly until you change the source or eject the magazine from the CD changer.

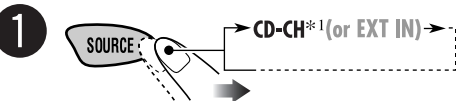

*1 If you have changed "EXT IN" setting to "EXT IN" (see page 18), you cannot select the CD changer. See also page 19, for using iPod or JVC D. player.

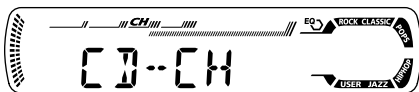

Selected disc number

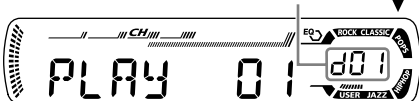

2 Select a disc.

For disc number from 01 – 06:



For disc number from 07 – 12:

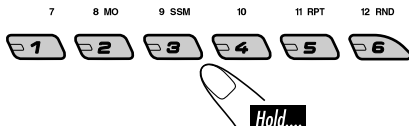

- When the current disc is an MP3 disc:



Selected folder number



Folder name*2

Disc information appears automatically (see page 14).



Elapsed playing time Current track number

*2 "ROOT" appears if no folder is included in the disc.

- When the current disc is an audio CD or a CD Text disc:

↓

CD Text: Disc title/performer →
Track title appears automatically
 (see page 14).

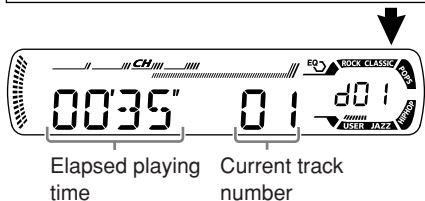

To locate a particular track (for CD) or folder (for MP3 or WMA discs) directly

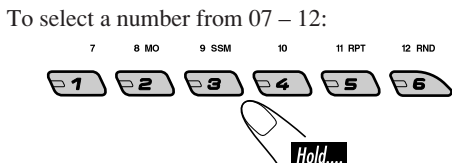
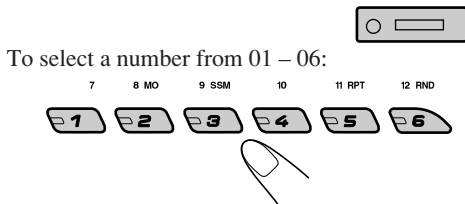

- To use folder search on MP3/WMA discs, it is required that folders are assigned with 2-digit numbers at the beginning of their folder names—01, 02, 03, and so on.

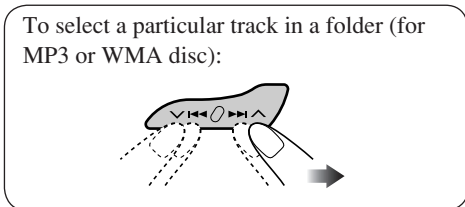

To fast-forward or reverse the track

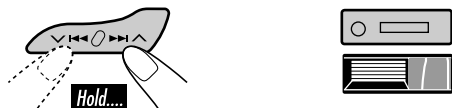

To go to the next or previous tracks

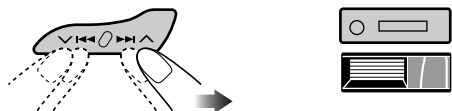

To go to the next or previous folders (only for MP3 or WMA discs)

For MP3 discs:

For WMA discs:

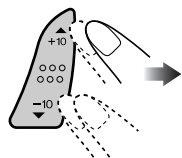

Other main functions

■ Skipping a track quickly during play



- For MP3 or WMA disc, you can skip a track within the same folder.

Ex.: To select track 32 while playing track 6

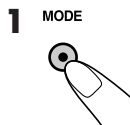

To be continued...

2

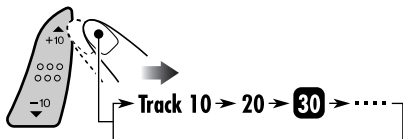

First time you press +10 or -10 button, the track skips to the nearest higher or lower track with a track number of multiple ten (ex. 10th, 20th, 30th).

Then each time you press the button, you can skip 10 tracks.

- After the last track, the first track will be selected and vice versa.

3

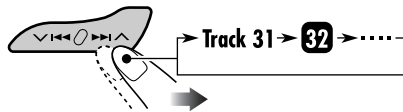

■ Prohibiting disc ejection



You can lock a disc in the loading slot.

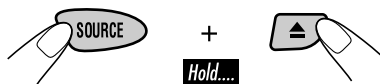

To cancel the prohibition, repeat the same procedure.

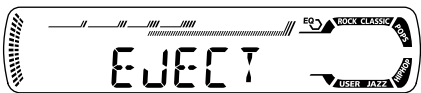

Changing the display information

DISP

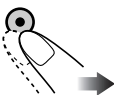

■ While playing an audio CD or a CD Text (/)



■ While playing an MP3 (/) or WMA disc ()

- When “TAG DISP” is set to “TAG ON” (see page 18)

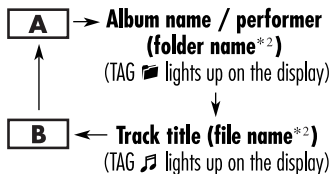

- When “TAG DISP” is set to “TAG OFF”

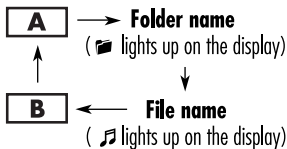

- A** : Clock and Current track/file number
- B** : Elapsed playing time and Current track/file number

*1 If the current disc is an audio CD, “NO NAME” appears.
 *2 If an MP3/WMA file does not have ID3 tags, folder name and file name appear. In this case, the TAG indicator will not light up.

Selecting the playback modes

You can use only one of the following playback modes at a time.

1 MODE



2 Select your desired playback mode.

Repeat play

11 RPT

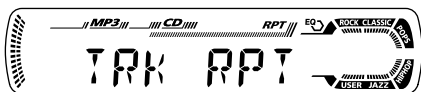

Ex.: When "TRK RPT" is selected while playing an MP3 disc in the unit

Mode

Plays repeatedly

- TRK RPT** : The current track.
 - RPT lights up.
- FLDR RPT***3 : All tracks of the current folder.
 - and RPT light up.
- DISC RPT***4 : All tracks of the current disc.
 - and RPT light up.
- RPT OFF** : Cancels.

Random play

12 RND



Ex.: When "DISC RND" is selected while playing an MP3 disc in the unit

Mode

Plays at random

- FLDR RND***3 : All tracks of the current folder, then tracks of the next folder and so on.
 - RND and light up.
- DISC RND** : All tracks of the current disc.
 - RND and light up.
- MAG RND***4 : All tracks of the inserted discs.
 - RND lights up.
- RND OFF** : Cancels.

*3 Only while playing an MP3 (/) or WMA () disc.

*4 Only while playing discs in the CD changer ().

Sound adjustments

Selecting preset sound modes (C-EQ: custom equalizer)

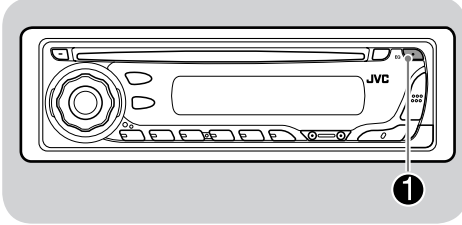

You can select a preset sound mode suitable to the music genre.

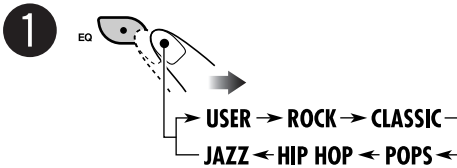

Indication	Preset values		
	BAS (bass)	TRE (treble)	LOUD (loudness)
USER (Flat sound)	00	00	OFF
ROCK Rock or disco music	+03	+01	ON
CLASSIC Classical music	+01	-02	OFF
POPS Light music	+04	+01	OFF
HIP HOP Funk or rap music	+02	00	ON
JAZZ Jazz music	+02	+03	OFF

Adjusting the sound

You can adjust the sound characteristics to your preference.

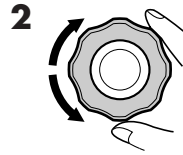
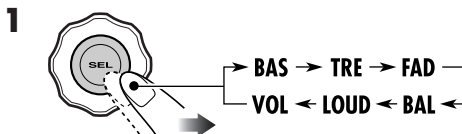

Indication pattern changes as you adjust the level.

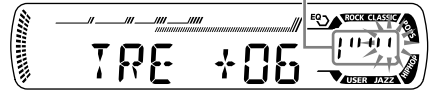

Ex.: When "TRE" is selected

Indication	Range
BAS *1 (bass) Adjust the bass.	-06 (min.) to +06 (max.)
TRE *1 (treble) Adjust the treble.	-06 (min.) to +06 (max.)
FAD *2 (fader) Adjust the front and rear speaker balance.	R06 (Rear only) to F06 (Front only)
BAL (balance) Adjust the left and right speaker balance.	L06 (Left only) to R06 (Right only)
LOUD *1 (loudness) Boost low and high frequencies to produce a well-balanced sound at low volume level.	LOUD ON ↓ LOUD OFF
VOL *3 (volume) Adjust the volume.	00 (min.) to 30 or 50 (max.)*4

*1 When you adjust the bass, treble, or loudness, the adjustment you have made is stored for the currently selected sound mode (C-EQ) including "USER."

*2 If you are using a two-speaker system, set the fader level to "00."

*3 Normally the control dial works as the volume control. So you do not have to select "VOL" to adjust the volume level.

*4 Depending on the amplifier gain control setting. (See page 18 for details.)

General settings — PSM

Basic operations

You can change PSM (Preferred Setting Mode) items listed (except for SID) in the table that follows.

3 Adjust the PSM item selected.

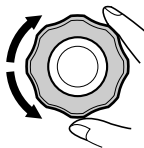

4 Repeat steps **2** and **3** to adjust the other PSM items if necessary.

5 Finish the procedure.



2 Select a PSM item.

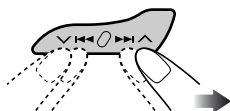

Ex.: When you select "DIMMER"

Indications	Selectable settings, [reference page]
DEMO Display demonstration	DEMO ON : [Initial]; Display demonstration will be activated automatically if no operation is done for about 20 seconds, [8]. DEMO OFF : Cancels.
CLOCK H Hour adjustment	1 – 12, [8] [Initial: 1 (1:00)]
CLOCK M Minute adjustment	00 – 59, [8] [Initial: 00 (1:00)]
CLK ADJ *1 Clock adjustment	AUTO : [Initial]; The built-in clock will be adjusted automatically using the clock data provided via the SIRIUS® radio channel. OFF : Cancels.

*1 Displayed only when SIRIUS radio is connected.

To be continued...

Indications	Selectable settings, [reference page]
T-ZONE *1, *2 Time zone	Select your residential area from one of the following time zone for clock adjustment. EASTERN [Initial] ⇄ ATLANTIC ⇄ NEWFOUND ⇄ ALASKA ⇄ PACIFIC ⇄ MOUNTAIN ⇄ CENTRAL ⇄ (back to the beginning)
DST *1, *2 Daylight savings time	Activate this if your residential area is subject to DST. ON : [Initial]; Activates daylight savings time. OFF : Cancels.
SID *1 SIRIUS® ID	The 12-digits SIRIUS identification number scrolls on the display after 5 seconds, [20]. • Press SEL to resume the previous display.
DIMMER Dimmer	ON : Activates dimmer. OFF : [Initial]; Cancels.
SCROLL *3 Scroll	ONCE : [Initial]; Scrolls the disc information once. AUTO : Repeats scrolling (5-second intervals in between). OFF : Cancels. • Pressing DISP for more than one second can scroll the display regardless of the setting.
EXT IN *4 External input	CHANGER : [Initial]; To use a JVC CD changer, an Apple iPod or a JVC D. player, [19]. EXT IN : To use another external component (other than SIRIUS DLP), [19].
TAG DISP Tag display	TAG ON : [Initial]; Shows the ID3 tag while playing MP3/WMA tracks, [14]. TAG OFF : Cancels.
AMP GAIN Amplifier gain control	You can change the maximum volume level of this unit. LOW PWR : VOL 00 – VOL 30 (Select this if the maximum power of the speaker is less than 50 W to avoid damaging the speaker.) HIGH PWR : [Initial]; VOL 00 – VOL 50
AREA Tuner channel interval	AREA EU : Select this when using the unit in an area other than North and South America. (FM: 50 kHz—manual tuning, 100 kHz—auto search; AM: 9 kHz) AREA US : [Initial]; Select this when using the unit in North or South America. (FM: 200 kHz; AM: 10 kHz)

*1 Displayed only when SIRIUS radio is connected.

*2 Displayed only when “CLK ADJ” is set to “AUTO.”

*3 Some characters or symbols will not be shown (and will be blanked) on the display.
(Ex. “ABC&!d#” ⇄ “ABCA D ”).

*4 Displayed only when one of the following sources is selected—FM, AM, or CD.

External component operations

This unit is ready for any Apple iPod® or JVC D. player control interface.

- For details, refer also to the manual supplied with the interface adapter for iPod®—KS-PD100 or D. player—KS-PD500.

Playing an external component

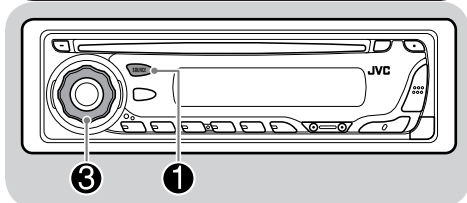

You can connect an external component to the CD changer jack on the rear using:

- Line Input Adapter—KS-U57 (not supplied) for any other components (except iPod or D. player).
- Interface adapter for iPod®—KS-PD100 (not supplied) for controlling iPod.
- D. player interface adapter—KS-PD500 (not supplied) for controlling D. player.

For connection, see Installation/Connection Manual (separate volume).

1 For selecting the external component connected using KS-U57.

- If “EXT IN” does not appear, see page 18 and select the external input (“EXT IN”).

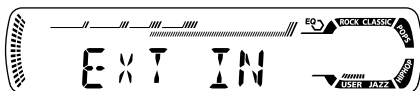
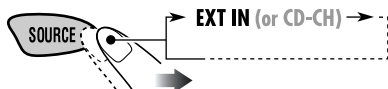

For selecting the iPod or D. player connected using KS-PD100 or KS-PD500.

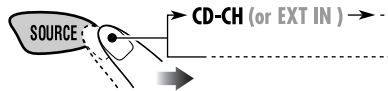

2 Turn on the connected component and start playing the source.

3 Adjust the volume.

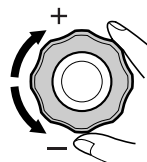

4 Adjust the sound as you want. (See page 16.)

SIRIUS® radio operations

About SIRIUS radio

SIRIUS is a satellite radio that can deliver digital-quality sound.

SIRIUS has 65 music channels which are all commercial-free and 50 channels of sports, news, and entertainment programs.

You can enjoy and control the SIRIUS radio digital entertainment channels from the unit by connecting the JVC SIRIUS radio DLP—Down Link Processor (optionally purchased) to the CD changer jack on the rear.

- You can also connect the JVC SIRIUS radio PnP (Plug and Play), KT-SR1000 or KT-SR2000, using the JVC SIRIUS radio adapter, KS-U100K (not supplied). By turning on the power of the unit, you can turn on/off the JVC PnP. However, you cannot control it from this unit.

GCI (Global Control Information) update:

- If channels are updated after subscription, updating starts automatically. “UPDATING” flashes and no sound can be heard.
- Update takes a few minutes to complete.
- During update, you cannot operate your SIRIUS radio.

Before operating your SIRIUS radio:

- For connection, see Installation/Connection Manual (separate volume).
- Refer also to the Instructions supplied with your SIRIUS radio.

Before you can listen to JVC DLP, activate your SIRIUS subscription after connection:

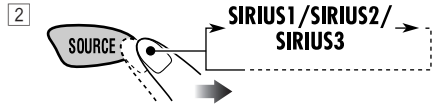
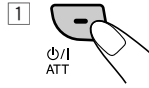

JVC DLP starts updating all the SIRIUS channels.

“UPDATING” flashes on the display for a few minutes. No sound can be heard during update.

Once completed, JVC DLP tunes in to the preset channel, CH184.

- 3 Check your SIRIUS ID, see page 18.
- 4 Contact SIRIUS on the internet at <http://activate.siriusradio.com/> to activate your subscription, or you can call SIRIUS toll-free at 1-888-539-SIRIUS (7474). “SUB UPDT PRESS ANY KEY” scrolls on the display once subscription has been completed.

Listening to the SIRIUS® radio

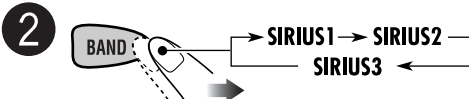
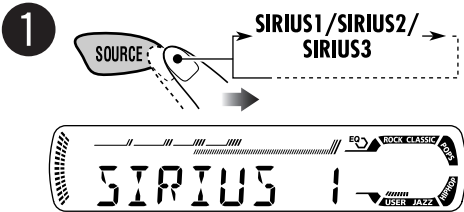
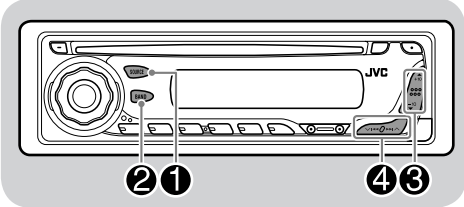

3 Select a category.

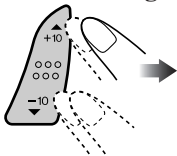

You can tune in to all the channels of every category by selecting "ALL." Selecting a particular category (SPORTS, ENTERTAINMENT, etc.) allows you to enjoy only the channels from the selected category.

4 Select a channel for listening.

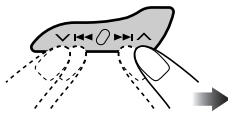

Press and hold these buttons to change the channels rapidly.

- When changing the category or channel, invalid and unsubscribed channels are skipped automatically.

Storing channels in memory

You can preset six channels for each band.
Ex.: Storing a channel into preset number 4.

1 Perform steps **1** to **4** on the left column, to tune in to a channel you want.

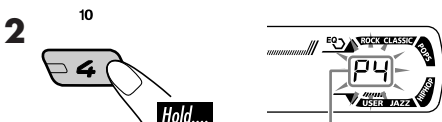

Preset number flashes for a while.

Listening to a preset channel

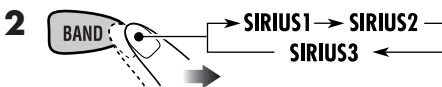
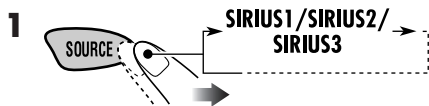

3 Select the preset channel (1 – 6) you want.

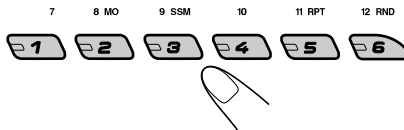

To change the display information while listening to a channel

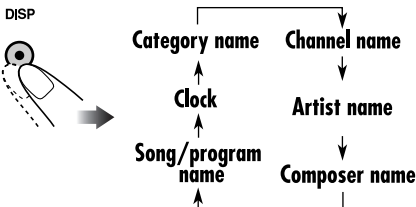

Maintenance

How to clean the connectors

Frequent detachment will deteriorate the connectors.

To minimize this possibility, periodically wipe the connectors with a cotton swab or cloth moistened with alcohol, being careful not to damage the connectors.

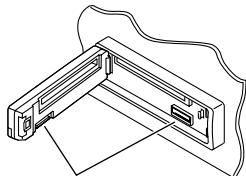

Connector

Moisture condensation

Moisture may condense on the lens inside the CD player in the following cases:

- After starting the heater in the car.
- If it becomes very humid inside the car.

Should this occur, the CD player may malfunction. In this case, eject the disc and leave the unit turned on for a few hours until the moisture evaporates.

How to handle discs

When removing a disc from its case, press down the center holder of the case and lift the disc out, holding it by the edges.

Center holder

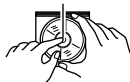

- Always hold the disc by the edges. Do not touch its recording surface.

When storing a disc into its case, gently insert the disc around the center holder (with the printed surface facing up).

- Make sure to store discs into the cases after use.

To keep discs clean

A dirty disc may not play correctly. If a disc does become dirty, wipe it with a soft cloth in a straight line from center to edge.



- Do not use any solvent (for example, conventional record cleaner, spray, thinner, benzene, etc.) to clean discs.

To play new discs

New discs may have some rough spots around the inner and outer edges. If such a disc is used, this unit may reject the disc.



To remove these rough spots, rub the edges with a pencil or ball-point pen, etc.

Do not use the following discs:

Warped disc



Sticker



Sticker residue

Disc



Stick-on label

More about this unit

Basic operations

Turning on the power

- By pressing SOURCE on the unit, you can also turn on the power. If the source is ready, playback also starts.

Turning off the power

- If you turn off the power while listening to a disc, disc play will start from where playback has been stopped previously, next time you turn on the power.

Selecting the sources

- When no disc is loaded in the unit, “CD” cannot be selected.
- Without connecting to the SIRIUS radio or CD changer, “SIRIUS” or “CD-CH” cannot be selected.

Tuner operations

Storing stations in memory

- During SSM search...
 - All previously stored stations are erased and stations are stored newly.
 - Received stations are preset in No. 1 (lowest frequency) to No. 6 (highest frequency).
 - When SSM is over, the station stored in No. 1 will be automatically tuned in.
- When storing a station manually, a previously preset station is erased when a new station is stored in the same preset number.

Disc operations

Caution for DualDisc playback

- The Non-DVD side of a “DualDisc” does not comply with the “Compact Disc Digital Audio” standard. Therefore, the use of Non-DVD side of a DualDisc on this product may not be recommended.

General

- This unit has been designed to reproduce CDs/CD Texts, and CD-Rs (Recordable)/CD-RWs (Rewritable) in audio CD (CD-DA), MP3 and WMA format.
- When a disc has been loaded, selecting “CD” for the playback source starts disc play.

Inserting a disc

- When a disc is inserted upside down, the disc automatically ejects.
- Do not insert 8 cm (3-3/16") discs (single CD) and unusual shape discs (heart, flower, etc.) into the loading slot.

Playing a disc

- While fast-forwarding or reversing on an MP3 or WMA disc, you can only hear intermittent sounds.

Playing a CD-R or CD-RW

- Use only “finalized” CD-Rs or CD-RWs.
- This unit can play back only the files of the same type which is first detected if a disc includes both audio CD (CD-DA) files and MP3/WMA files.
- This unit can play back multi-session discs; however, unclosed sessions will be skipped while playing.
- Some CD-Rs or CD-RWs may not play back on this unit because of their disc characteristics, and for the following causes:
 - Discs are dirty or scratched.
 - Moisture condensation occurs on the lens inside the unit.
 - The pickup lens inside the unit is dirty.
 - CD-R/CD-RW on which the files are written with “Packet Write” method.
 - There are improper recording conditions (missing data, etc.) or media conditions (stain, scratch, warp, etc.).
- CD-RWs may require a longer readout time since the reflectance of CD-RWs is lower than that of regular CDs.

To be continued...

- Do not use the following CD-Rs or CD-RWs:
 - Discs with stickers, labels, or protective seal stuck to the surface.
 - Discs on which labels can be directly printed by an ink jet printer.
 Using these discs under high temperatures or high humidity may cause malfunctions or damage to discs.

Playing an MP3/WMA disc

- This unit can play back MP3/WMA files with the extension code <.mp3> or <.wma> (regardless of the letter case—upper/lower).
- This unit can show the names of albums, artists (performer), and ID3 Tag (Version 1.0, 1.1, 2.2, 2.3, or 2.4) for MP3 files and for WMA files.
- This unit can handle only one-byte characters. No other characters can be correctly displayed.
- This unit can play back MP3/WMA files meeting the conditions below:
 - Bit rate: 8 kbps — 320 kbps
 - Sampling frequency:
 - 48 kHz, 44.1 kHz, 32 kHz (for MPEG-1)
 - 24 kHz, 22.05 kHz, 16 kHz (for MPEG-2)
 - Disc format: ISO 9660 Level 1/ Level 2, Romeo, Joliet, Windows long file name
- The maximum number of characters for file/ folder names vary among the disc format used (includes 4 extension characters—<.mp3> or <.wma>).
 - ISO 9660 Level 1: up to 12 characters
 - ISO 9660 Level 2: up to 31 characters
 - Romeo: up to 128 characters
 - Joliet: up to 64 characters
 - Windows long file name: up to 128 characters
- This unit can recognize the total of 512 files, of 200 folders, and of 8 hierarchies.

- This unit can play back the files recorded in VBR (variable bit rate).
The files recorded in VBR have a discrepancy in elapsed time display, and do not show the actual elapsed time. This difference becomes noticeable especially after performing the search function.
- This unit cannot play back the following files:
 - MP3 files encoded with MP3i and MP3 PRO formats.
 - MP3 files encoded in an unappropriated format.
 - MP3 files encoded with Layer 1/2.
 - WMA files encoded with lossless, professional, and voice format.
 - WMA files which are not based upon Windows Media® Audio.
 - WMA formatted files copy-protected with DRM.
 - Files which have the data such as WAVE, ATRAC3, etc.
- The search function works but search speed is not constant.

Changing the source

- If you change the source, playback also stops (without ejecting the disc).
Next time you select “CD” for the playback source, disc play starts from where it has been stopped previously.

Ejecting a disc

- If the ejected disc is not removed within 15 seconds, the disc is automatically inserted again into the loading slot to protect it from dust. (Disc will not play this time.)

General settings—PSM

- If you change the “AMP GAIN” setting from “HIGH PWR” to “LOW PWR” while the volume level is set higher than “VOL 30,” the unit automatically changes the volume level to “VOL 30.”

Troubleshooting

What appears to be trouble is not always serious. Check the following points before calling a service center.

	Symptoms	Remedies/Causes
General	<ul style="list-style-type: none"> • Sound cannot be heard from the speakers. 	<ul style="list-style-type: none"> • Adjust the volume to the optimum level. • Check the cords and connections.
	<ul style="list-style-type: none"> • The unit does not work at all. 	Reset the unit (see page 2).
FM/AM	<ul style="list-style-type: none"> • SSM automatic presetting does not work. 	Store stations manually.
	<ul style="list-style-type: none"> • Static noise while listening to the radio. 	Connect the antenna firmly.
Disc playback	<ul style="list-style-type: none"> • Disc automatically ejects. 	Insert the disc correctly.
	<ul style="list-style-type: none"> • CD-R/CD-RW cannot be played back. • Tracks on the CD-R/CD-RW cannot be skipped. 	<ul style="list-style-type: none"> • Insert a finalized CD-R/CD-RW. • Finalize the CD-R/CD-RW with the component which you used for recording.
	<ul style="list-style-type: none"> • Disc can be neither played back nor ejected. 	<ul style="list-style-type: none"> • Unlock the disc (see page 14). • Eject the disc forcibly (see page 2).
	<ul style="list-style-type: none"> • Disc sound is sometimes interrupted. 	<ul style="list-style-type: none"> • Stop playback while driving on rough roads. • Use an unscratched disc. • Check the cords and connections.
	<ul style="list-style-type: none"> • “NO DISC” appears on the display. 	<ul style="list-style-type: none"> • Insert a correct disc into the loading slot.
MP3/WMA playback	<ul style="list-style-type: none"> • Disc cannot be played back. 	<ul style="list-style-type: none"> • Use a disc with MP3/WMA tracks recorded in the format compliant with ISO 9660 Level 1, Level 2, Romeo, or Joliet. • Add the extension code <.mp3> or <.wma> to the file names.
	<ul style="list-style-type: none"> • Noise is generated. 	Skip to another track or change the disc. (Do not add the extension code <.mp3> or <.wma> to non-MP3 or WMA tracks.)
	<ul style="list-style-type: none"> • A longer readout time is required (“CHECK” keeps flashing on the display). 	Do not use too many hierarchies and folders.
	<ul style="list-style-type: none"> • Tracks do not play back in the order you have intended them to play. 	Playback order is determined when the files are recorded.
	<ul style="list-style-type: none"> • Elapsed playing time is not correct. 	This sometimes occurs during play. This is caused by how the tracks are recorded on the disc.
	<ul style="list-style-type: none"> • “NO FILES” appears on the display. 	Insert a disc that contains MP3/WMA tracks.
	<ul style="list-style-type: none"> • Correct characters are not displayed (e.g. album name). 	This unit can only display alphabets (capital: A – Z), numbers, and a limited number of symbols.

	Symptoms	Remedies/Causes
CD changer	• “NO DISC” appears on the display.	Insert a disc into the magazine.
	• “NO MAG” appears on the display.	Insert the magazine.
	• “RESET 8” appears on the display.	Connect this unit and the CD changer correctly and press the reset button of the CD changer.
	• “RESET 1” – “RESET 7” appears on the display.	Press the reset button of the CD changer.
	• The CD changer does not work at all.	Reset the unit (see page 2).
SIRIUS	• “CALL 1-888-539-SIRIUS TO SUBSCRIBE” scrolls on the display.	Start subscribing (see page 20).
	• “NO SIGNAL” scrolls on the display.	Move to an area with stronger signals.
	• “NO ANTENNA” scrolls on the display.	Connect the antenna firmly.
	• “NO CH” appears on the display for about 5 seconds, then returns to the previous display.	Select another channel or continue listening to the previous channel.
	• “NO (information)*” appears or scrolls on the display.	No text information for the selected channel.
	• No sound can be heard, “UPDATING” flashes on the display.	The unit is updating the channel information. Updating takes a few minutes to complete.
	• SIRIUS radio does not work at all.	Reconnect the SIRIUS radio after a few seconds.

* NO CATEGORY, NO CHANNEL, NO ARTIST, NO COMPOSER, or NO SONG/PROGRAM

Specifications

AUDIO AMPLIFIER SECTION

Power Output:

18 W RMS \times 4 Channels at 4 Ω
and \leq 1% THD+N

Signal to Noise Ratio:

80 dBA (reference: 1 W into 4 Ω)



Load Impedance: 4 Ω (4 Ω to 8 Ω allowance)

Tone Control Range:

Bass: \pm 10 dB at 100 Hz

Treble: \pm 10 dB at 10 kHz

Frequency Response: 40 Hz to 20 000 Hz

Line-Out Level/Impedance:

2.5 V/20 k Ω load (full scale)

Output Impedance: 1 k Ω

Other terminals: CD changer

TUNER SECTION

Frequency Range:

FM: 87.5 MHz to 107.9 MHz

(with channel interval set to 200 kHz)

87.5 MHz to 108.0 MHz

(with channel interval set to 50 kHz)

AM: 530 kHz to 1 710 kHz

(with channel interval set to 10 kHz)

531 kHz to 1 602 kHz

(with channel interval set to 9 kHz)

[FM Tuner]

Usable Sensitivity: 11.3 dBf (1.0 μ V/75 Ω)

50 dB Quieting Sensitivity:

16.3 dBf (1.8 μ V/75 Ω)

Alternate Channel Selectivity (400 kHz): 65 dB

Frequency Response: 40 Hz to 15 000 Hz

Stereo Separation: 35 dB

Capture Ratio: 1.5 dB

[AM Tuner]

Sensitivity: 20 μ V

Selectivity: 35 dB

CD PLAYER SECTION

Type: Compact disc player

Signal Detection System: Non-contact optical pickup (semiconductor laser)

Number of channels: 2 channels (stereo)

Frequency Response: 5 Hz to 20 000 Hz

Dynamic Range: 96 dB

Signal-to-Noise Ratio: 98 dB

Wow and Flutter: Less than measurable limit

MP3 decoding format:

MPEG1/2 Audio Layer 3

Max. Bit Rate: 320 Kbps

WMA (Windows Media[®] Audio) decoding format:

Max. Bit Rate: 192 Kbps

GENERAL

Power Requirement:

Operating Voltage:

DC 14.4 V (11 V to 16 V allowance)

Grounding System: Negative ground

Allowable Operating Temperature:

0°C to +40°C (32°F to 104°F)

Dimensions (W \times H \times D):

Installation Size (approx.):

182 mm \times 52 mm \times 150 mm

(7-3/16" \times 2-1/16" \times 5-15/16")

Panel Size (approx.):

188 mm \times 58 mm \times 11 mm

(7-7/16" \times 2-5/16" \times 7/16")

Mass (approx.):

1.4 kg (3.1 lbs) (excluding accessories)

Design and specifications are subject to change without notice.

If a kit is necessary for your car, consult your telephone directory for the nearest car audio speciality shop.

- Microsoft and Windows Media are either registered trademarks or trademarks of Microsoft Corporation in the United States and/or other countries.



Having TROUBLE with operation?

Please reset your unit

Refer to page of How to reset your unit

Still having trouble??

USA ONLY

Call 1-800-252-5722

<http://www.jvc.com>

We can help you!

JVC



EN, SP

© 2005 Victor Company of Japan, Limited

0705DTSMDTJEIN

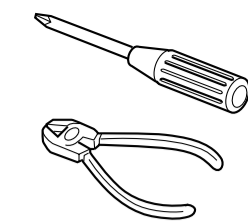

ENGLISH

You need the installation kits which corresponds to your car.

- Mark all the check boxes () to make sure you have follow the instructions and the listed parts.

Check the battery system in your car.



Parts list for installation and connection

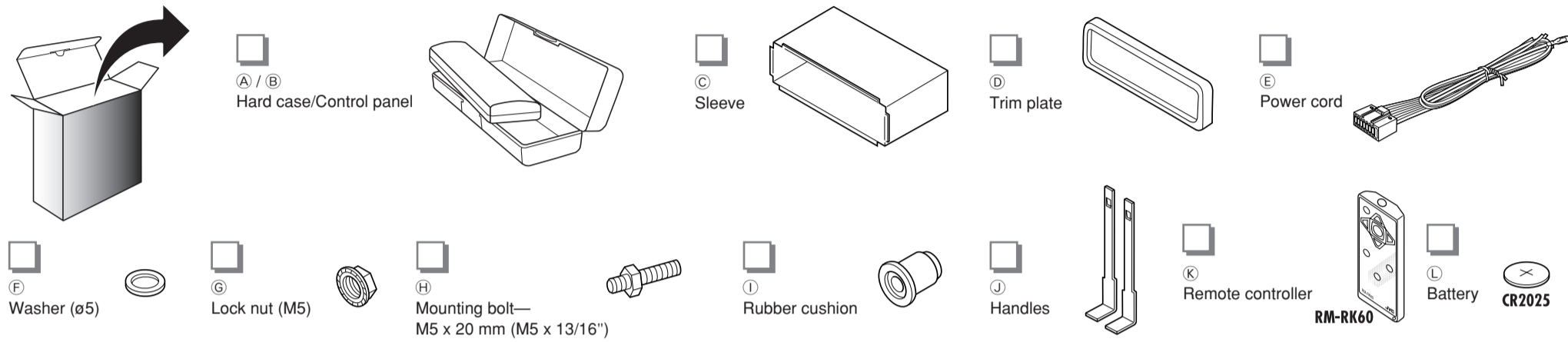

INSTALLATION (IN-DASH MOUNTING)

If you are not sure how to install this unit correctly, consult your JVC car audio dealer.

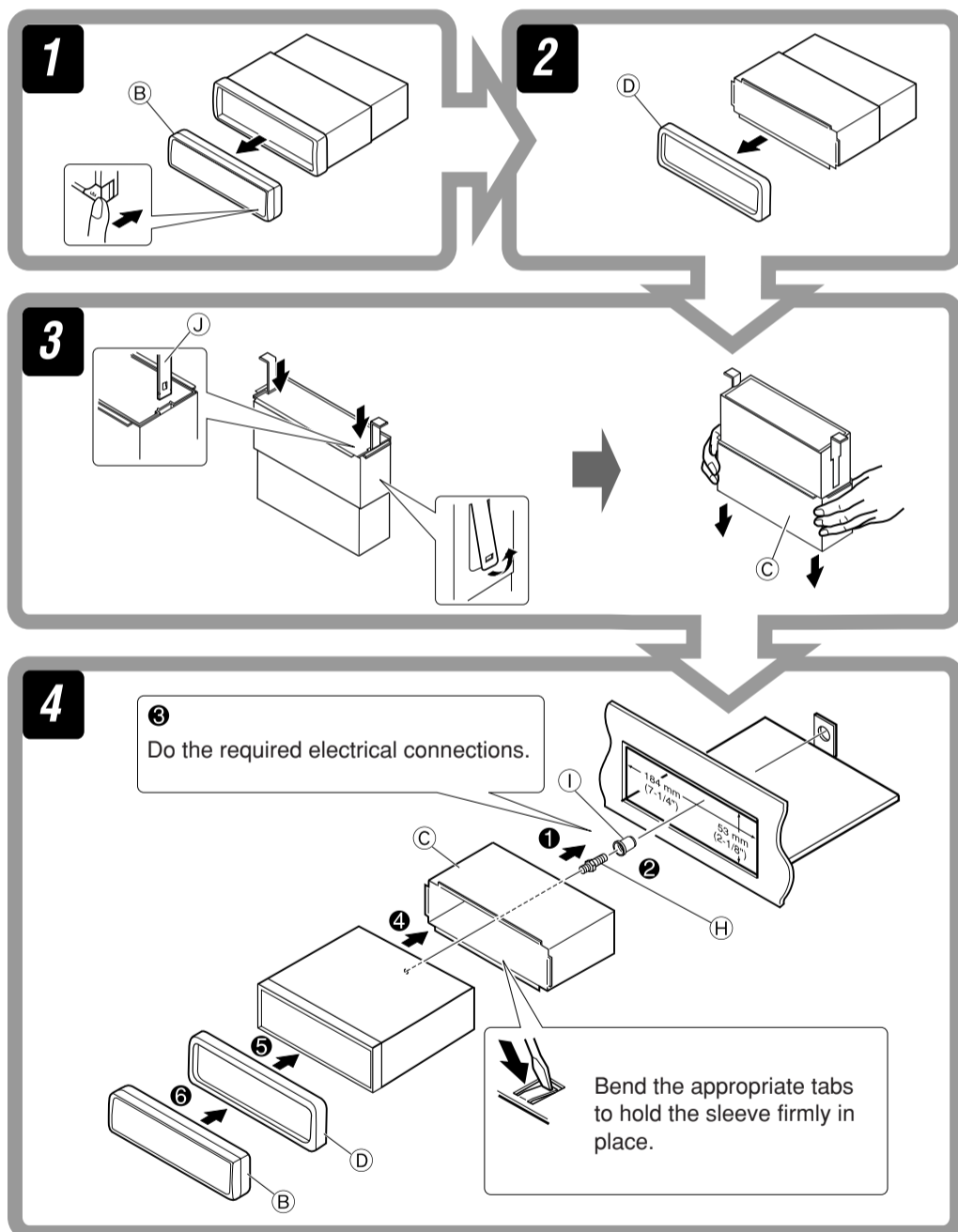

Removing the unit

Before removing the unit, release the rear section.

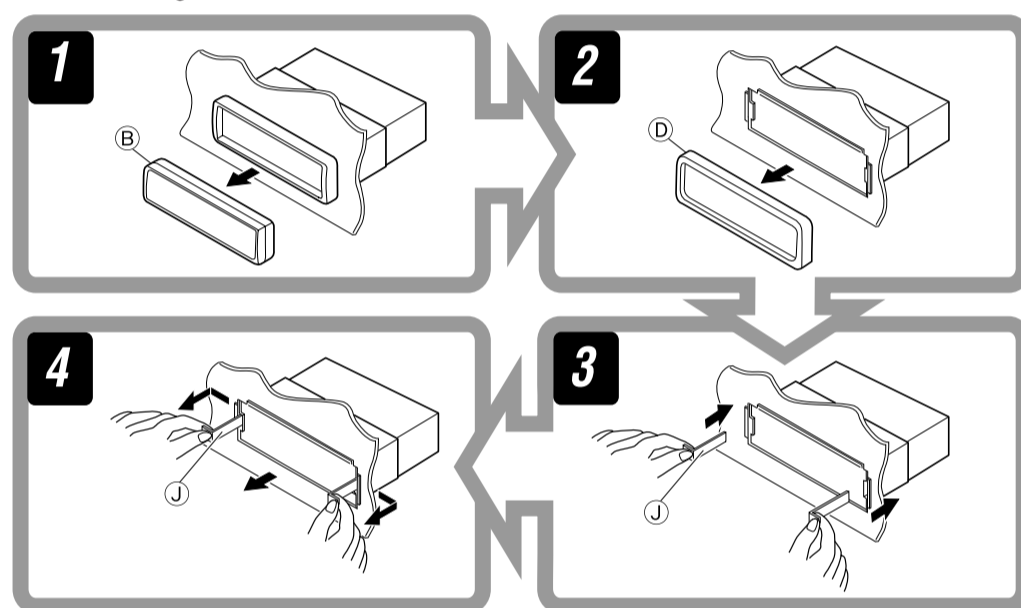

ELECTRICAL CONNECTIONS

Make sure to disconnect the battery's negative terminal.

- Be sure to ground this unit to the car's chassis again after installation.

Note:

It is recommended to connect to the speakers with maximum power of more than 50 W (both at the rear and at the front, with an impedance of 4 Ω to 8 Ω). If the maximum power is less than 50 W, change "AMP GAIN" setting to prevent the speakers from being damaged (see page 18 of the INSTRUCTIONS).

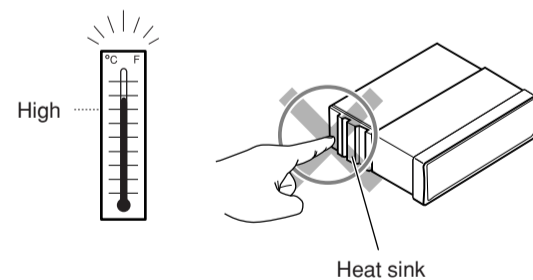

When using the optional stay

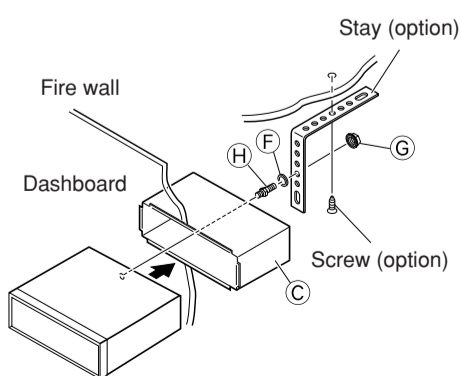

Install the unit at an angle of less than 30°.

When installing the unit without using the sleeve

In a Toyota for example, first remove the car radio and install the unit in its place.

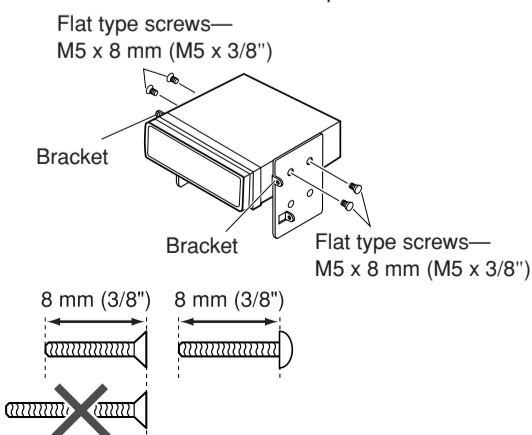

TROUBLESHOOTING

- **The fuse blows.**
 - * Are the red and black leads connected correctly?
- **Power cannot be turned on.**
 - * Is the yellow lead connected?
- **No sound from the speakers.**
 - * Is the speaker output lead short-circuited?
- **Sound is distorted.**
 - * Is the speaker output lead grounded?
 - * Are the "-" terminals of L and R speakers grounded in common?
- **Noise interfere with sounds.**
 - * Is the rear ground terminal connected to the car's chassis using shorter and thicker cords?
- **Unit becomes hot.**
 - * Is the speaker output lead grounded?
 - * Are the "-" terminals of L and R speakers grounded in common?
- **This unit does not work at all.**
 - * Have you reset your unit?

A Typical Connections

Before connecting: The leads of the power cord and those of the connector from the car body may be different in color.

B Connecting the external amplifier

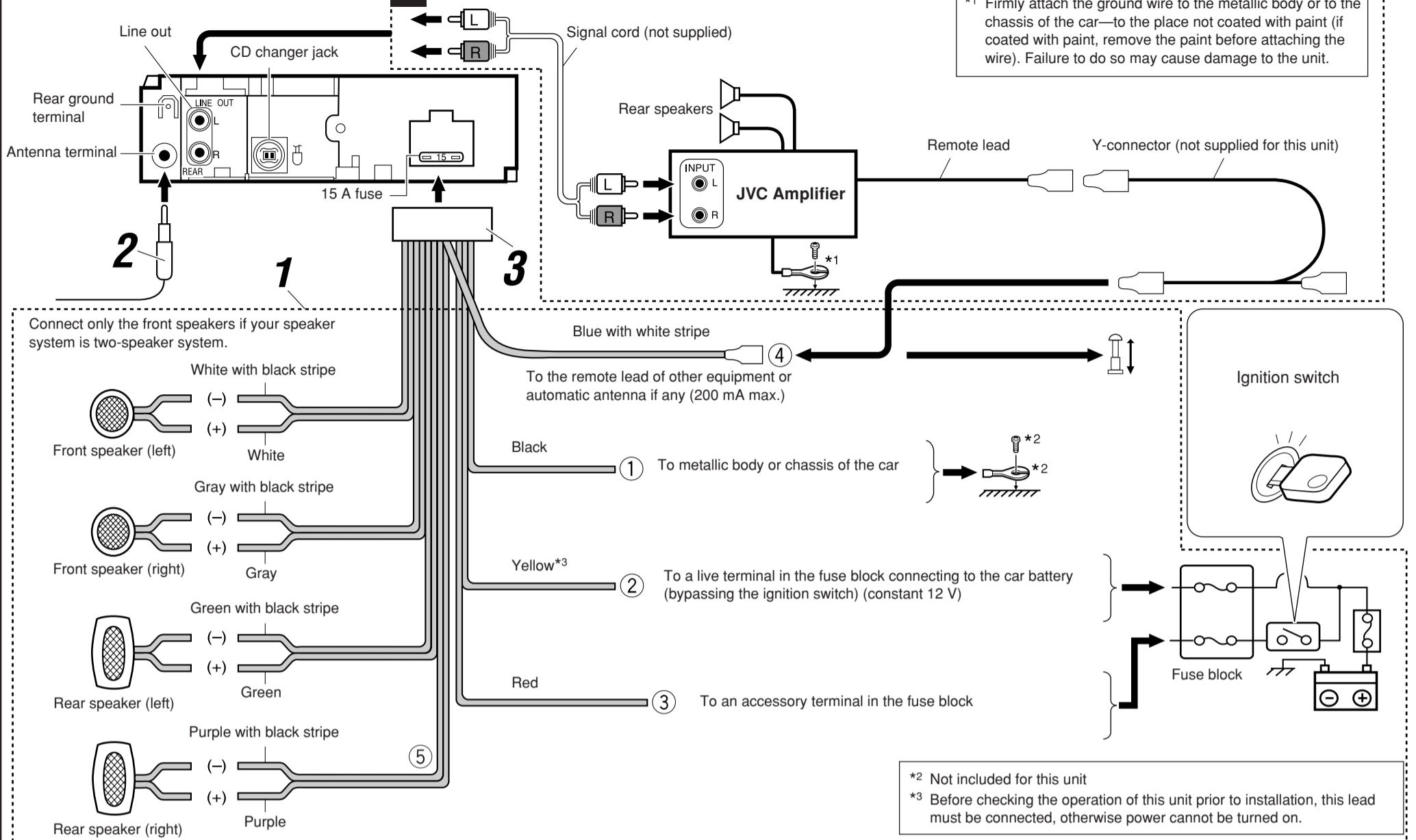

PRECAUTIONS on power supply and speaker connections:

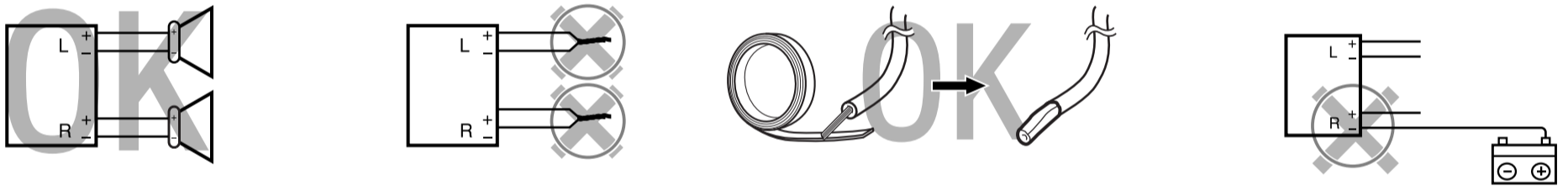

C Connecting other external components

JVC CD changer, JVC SIRIUS® radio (DLP: Down Link Processor), Apple iPod®, or JVC D. player

- Set "EXT IN" to "CHANGER" (see page 18 of the INSTRUCTIONS).

You can connect these components in series as illustrated below. The iPod or D. player can be connected using an interface adapter (not supplied)—KS-PD100 (for iPod) or KS-PD500 (for D. player).

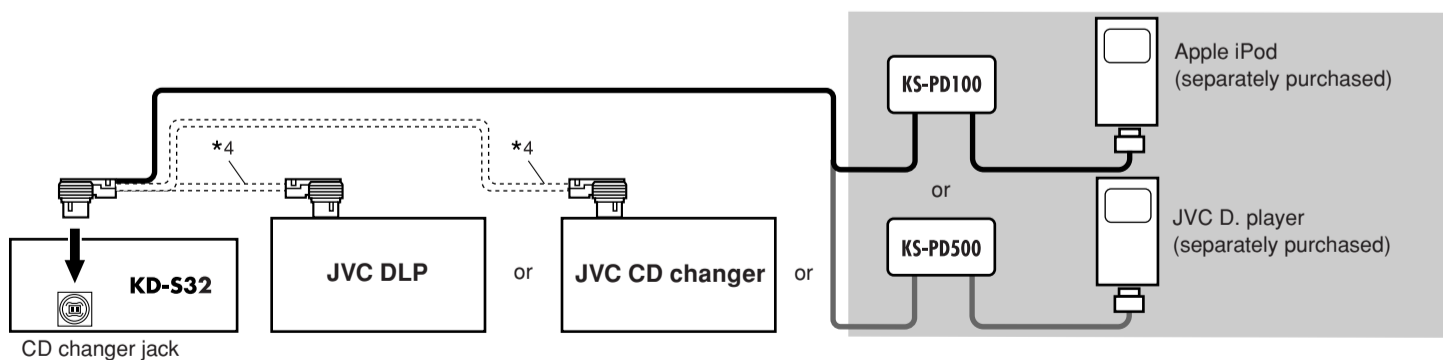
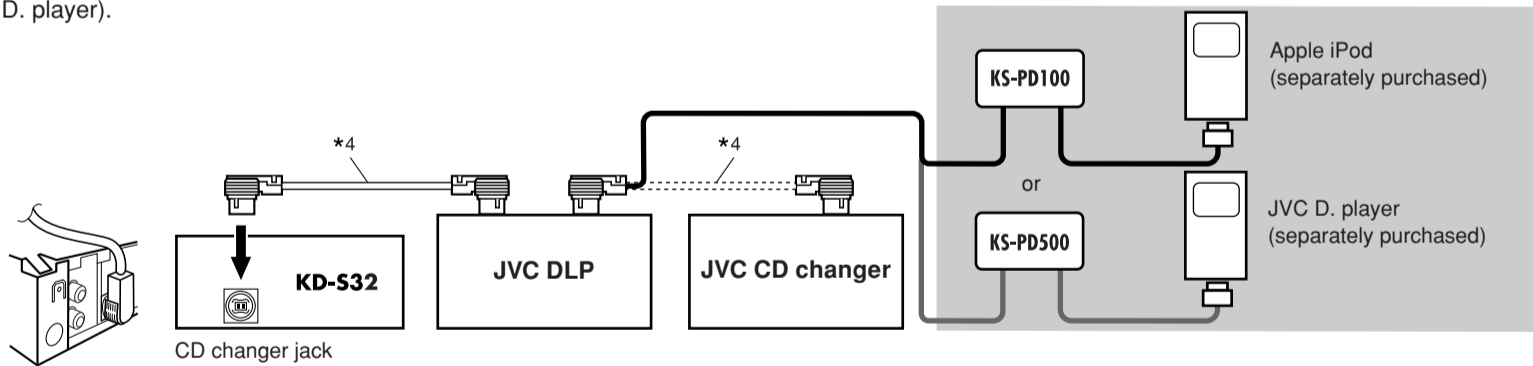

JVC SIRIUS® radio (PnP: Plug and Play) and External component

- Set "EXT IN" to "EXT IN" (see page 18 of the INSTRUCTIONS).

You can also connect JVC PnP through this unit using JVC SIRIUS radio adapter, KS-U100K (not supplied).

